



# DATA SHEET FOR FLP PUSH BUTTON STATION (LCS) (DIRECT ENTRY)

## TECHNICAL DATA:

- PRODUCT : CAT. NO. - PBS/2C/2025
- ENCLOSURE : FLAME PROOF (Ex -d ), Gas Group IIA , IIB, IIC  
As per IS/IEC 60079-1 : 2014
- PROTECTION : WEATHER PROOF IP – 66 AS PER IS/IEC 60529:2001  
(Reaffirmed 2014)
- AREA & TEMP. CLASS : Ex db IIC T6 Gb ( EX tb / tc IIIC T85 C Db/Dc  
(ZONE 1 & 2 & Zone 21 & 22)
- CERTIFICATION : CIMFR, BIS, PESO
- TEMP CLASS : T6
- MATERIAL : DIE CAST ALUMINIUM ALLOY
- FINISH : EPOXY POWDER COATED SHADE AS PER IS : 5
- EARTHING : 1 No INTERNAL & 2 No's EXTERNAL
- HARDWARE : STAINLESS STEEL
- GASKET : 'O' RING ENDLESS GASKET NEOPRENE / SILICON
- NAME PLATE : SS NAME PLATE CUM WARNING PLATE
- ENTRIES : 2 Nos M20 / ½ " NPT / EQUIVALENT



### OPTIONS

SR.NO	PARTICULAR	OPTIONS
1.	MATERIAL OF CONSTRUCTION	STAINLESS STEEL
2.	GLAND & PLUG	BRASS / SS / ALUMINIUM
3.	COLOUR SHADE	631, 632, 355, 7031, 7032 etc.
4.	ELEMENT	1 NO / 1 NC OR AS PER REQUIREMENT
5.	CANOPY	M.S POWDER COATED / FRP / GI

### SELECTION CHART

SR.NO	COMBINATION
1.	ONLY EMERGENCY OFF
2.	ONLY OFF
3.	ON/OFF
4.	INDICATION LAMP
5.	ON/OFF WITH LAMP

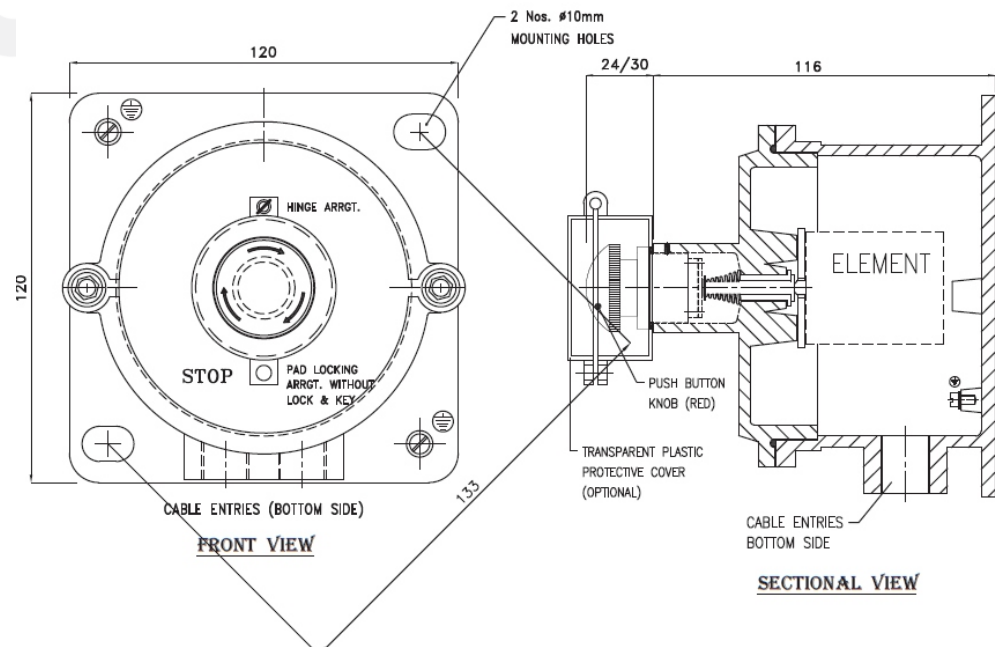

**NOTE:- PERMUTATION & COMBINATION OF COMPONENTS / ENTRIES AS PER CUSTOMER REQUIREMENT**